

Dati tecnici/Technical data

Sistema di bloccaggio pannello <i>Panel locking system</i>	Morsa orizzontale e verticale <i>Horizontal and vertical vise/clamp</i>
Hardware	Omron
Software supervisione <i>Supervision software</i>	Stema Pegasus
Dimensioni pannelli <i>Panel dimensions</i>	Lunghezza = Illimitata <i>Length = unlimited</i> Altezza = min. 50 mm – max. 1100/1400 mm <i>Height = min. 50 mm – max. 1100/1400 mm</i> Spessore = min. 10 mm - max. 50 mm <i>Thickness = min. 10 mm - max. 50 mm</i>
Gruppi di lavorazione spine n.01 gruppo in entrata n.01 gruppo in uscita <i>Working groups for dowels</i> <i>n.01 group on machine entry</i> <i>n.01 group on machine exit</i>	Ciascun gruppo è completo di: Nr.1 testa verticale 5x32 mandrini indipendenti Nr.1 gruppo inserimento colla e spine Nr. 1 Revolver (Y1, Z1, C1) <i>Each group is composed of:</i> <i>Nr.1 vertical drilling head 5x32 independent spindles</i> <i>Nr.1 inserting unit for glue and dowels</i> <i>Nr. 1 Revolver (Y1, Z1, C1)</i>
Gruppo optional di foratura <i>Optional drilling group</i>	Revolver 10 posizioni (assi Y2, Z2, C2 indipendenti) <i>Revolver with 10 positions (independent Y2, Z2, C2 axis)</i>
Gruppo optional di inserimento <i>Optional inserting group</i>	Unità inserimento per reggi-ripiani, bussola e basetta <i>Inserting group for shel-supports, bushes and hinge-plates</i>



KUMA



STEMA Srl
22040 BRENNNA (CO)
Via del Fontanile, 4
Tel 031.763974
www.stemasrl.eu
info@stemasrl.eu

Fronte
Front

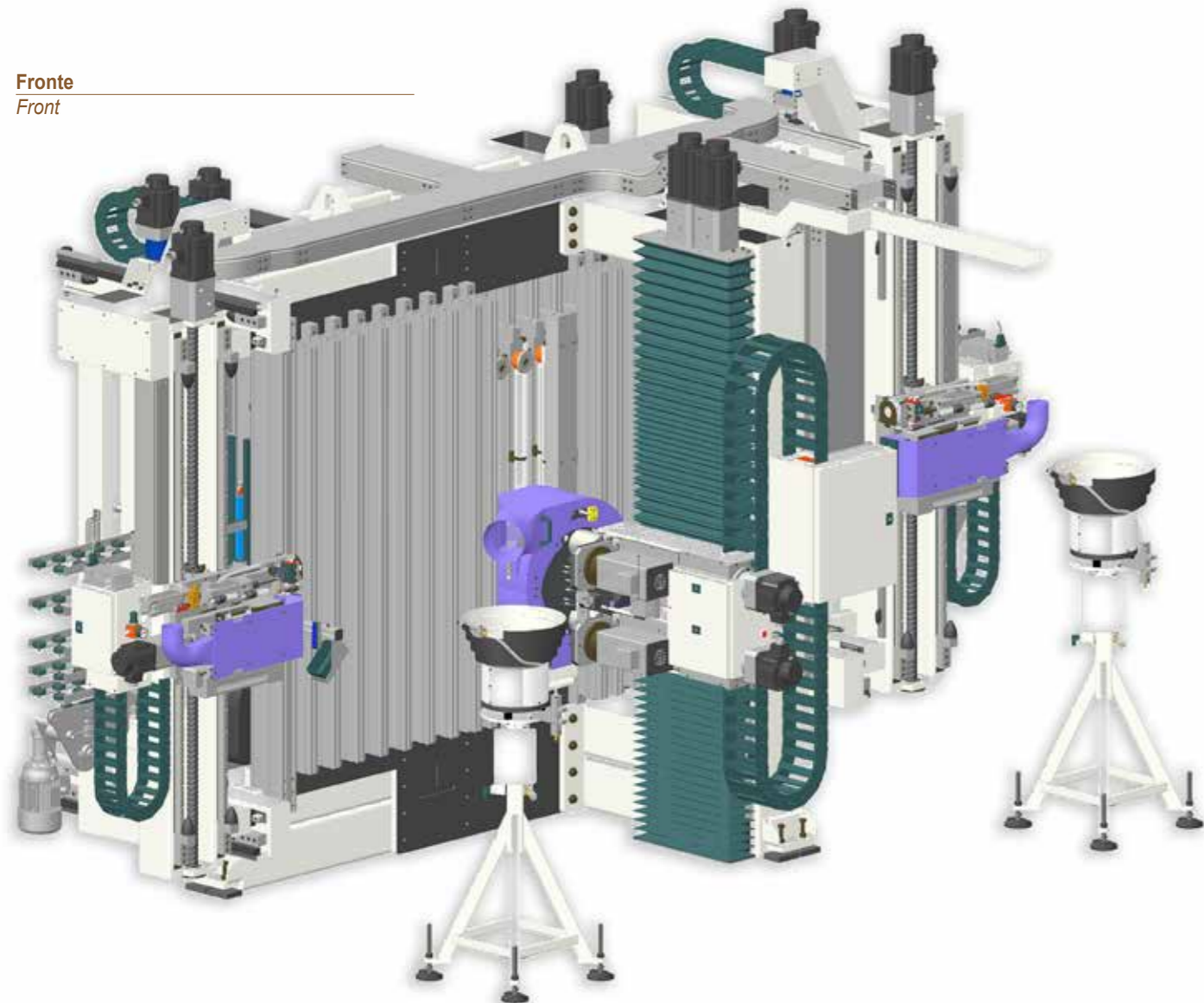

Retro
Back

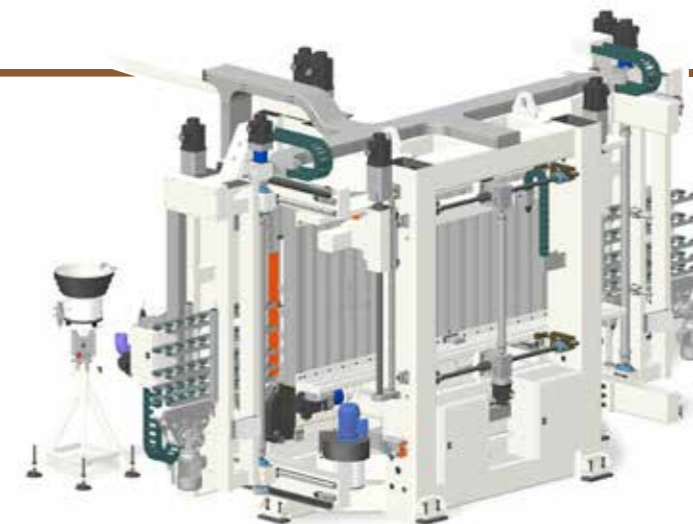

Colla spine
Glue-dowels



Colla spine reggipiano
Glue-dowels-shelf supports



Reggipiani
Shelf supports

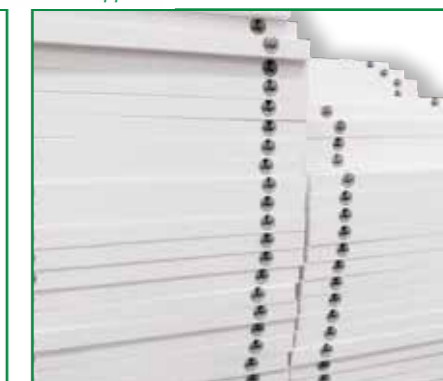

Macchina verticale a CN per foratura, fresatura, pantografatura ed inserimento di colla e spine su elementi orizzontali dei mobili
Vertical NC machine for drilling, routing, sawing and inserting glue and dowels on horizontal elements of cabinets

