

Dati tecnici/Technical data

Specifiche tecniche Technical data	Pannelli lavorabili singolarmente Singular working panel	Pannelli lavorabili in coppia Double working panels
Lunghezza/Length	mm 200/2500	mm 200/1250
Larghezza/Width	mm 120/800	
Spessore/Thickness	mm 10/50	

CB86

Gruppi di foratura Drilling unit	1 testa/head
Gruppi di inserimento Insertion unit	1 cerniera/hinge

CB90

Gruppi di foratura Drilling unit	da 2 a 6 teste/head
Gruppi di inserimento Insertion unit	da 2 a 6 cerniere/hinges



CB86-CB90

CB - ED.01

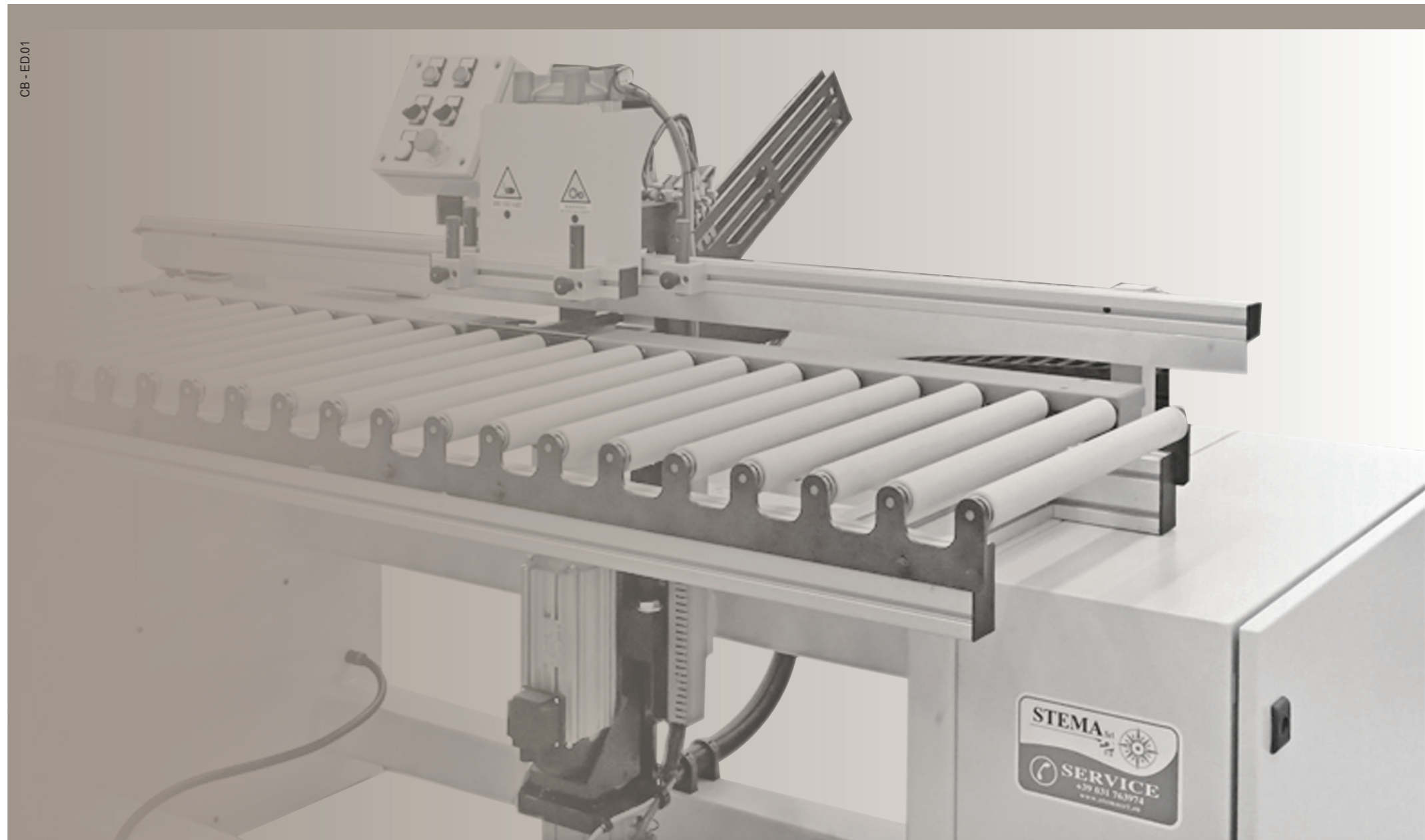

STEMA Srl
22040 BRENNIA (CO)
Via del Fontanile, 4
Tel 031.763974
www.stemasrl.eu
info@stemasrl.eu

CB86

Macchina orizzontale con 1 testa per foratura e inserimento cerniere. Caricamento manuale.

Horizontal machine with 1 head for drilling and insertion of hinges. Manual loading.

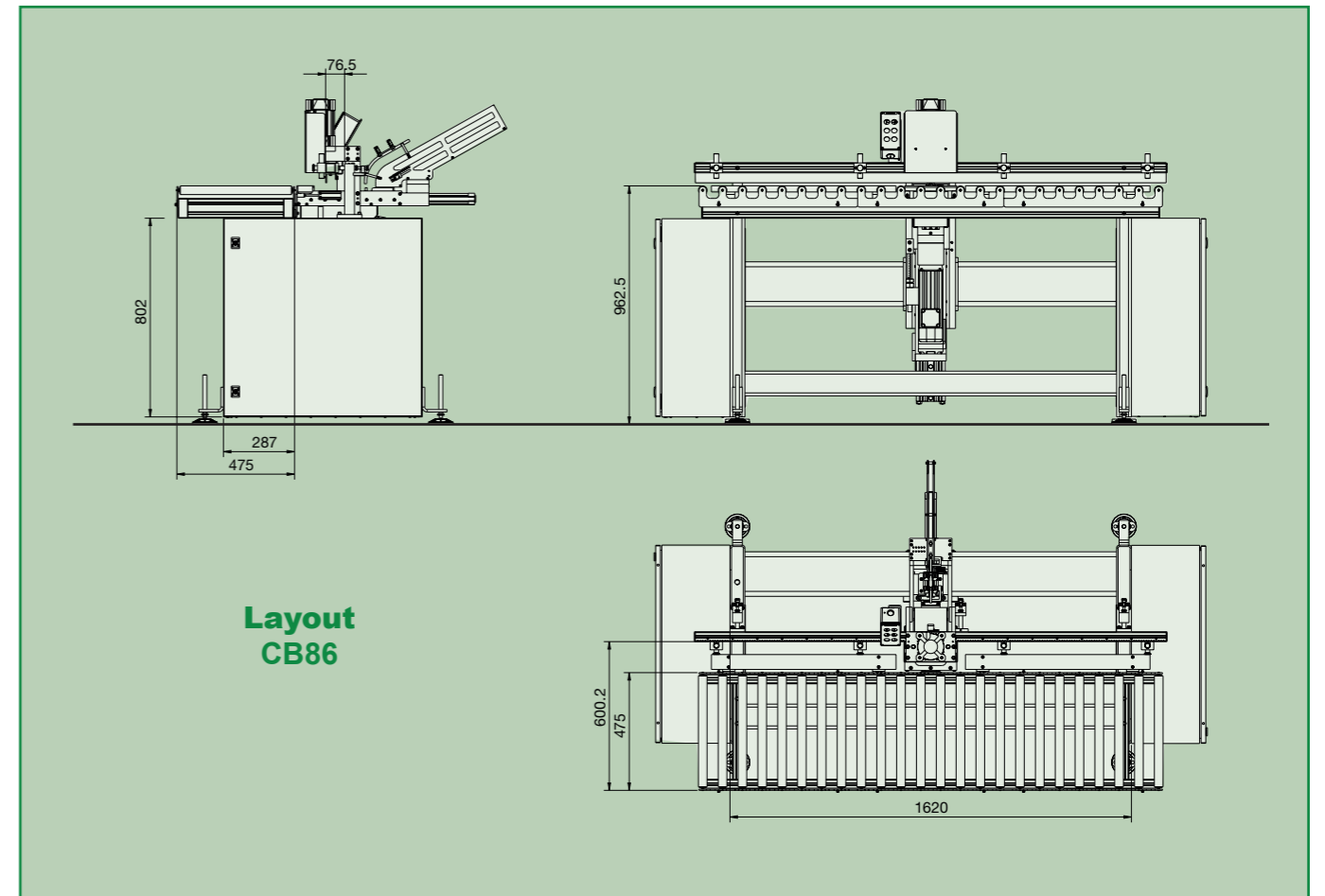
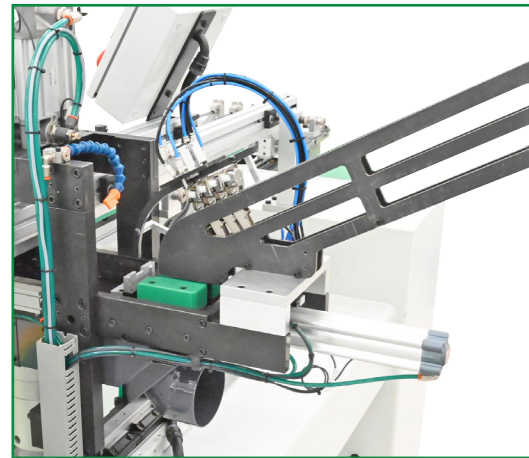

CB90

Macchina orizzontale con 4 teste per foratura e inserimento cerniere. Caricamento manuale.

Horizontal machine with 4 heads for drilling and insertion hinges. Manual loading.

