

## Dati tecnici/Technical data

Specifiche tecniche Technical data	Pannelli lavorabili singolarmente Singolar working panel
Lunghezza/Length	mm 240/3000
Larghezza/Width	mm 75/800
Spessore/Thickness	mm 12/50
Gruppi di inserimento Insertion unit	Tipo Type
Asse/Axis Y1 (*)	Basetta Hinge plate
	Basetta Hinge plate
	Supporto ripiano Shelf support
Asse/Axis Y2 (*)	Bussola avvitata Screwed compass
	Bussola avvitata Screwed compass

\* Personalizzabile  
Customisable



# MEROPE



STEMA Srl  
22040 BRENNNA (CO)  
Via del Fontanile, 4  
Tel 031.763974  
www.stemasrl.eu  
info@stemasrl.eu

Fronte  
Front

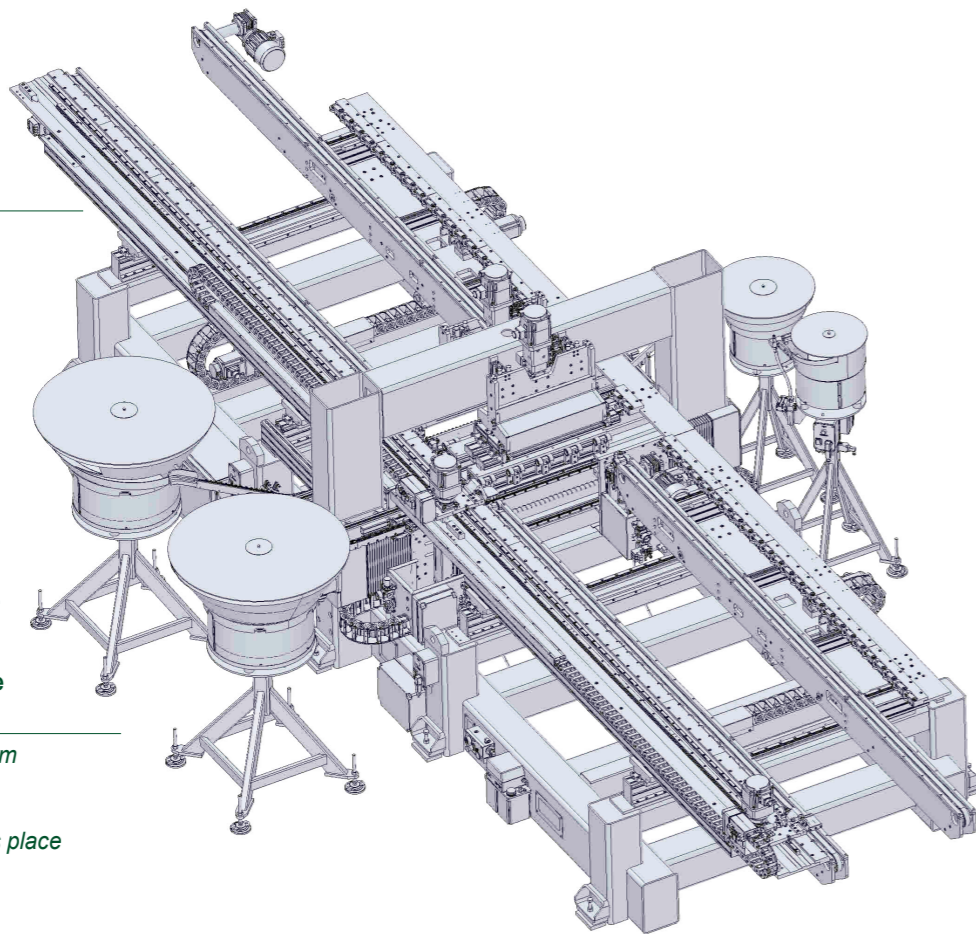

Macchina a CN realizzata per eseguire lavorazioni di inserimento ferramenta sulla faccia inferiore del pezzo. La movimentazione del pannello avviene automaticamente in orizzontale tramite apposite pinze.

NC machine designed to perform hardware insertion operations on the lower side of the piece. The handling of the panel takes place automatically and horizontally by means of special clamps.

Gruppi di inserimento sul lato inferiore del pannello  
Insertion groups on the lower side of the panel

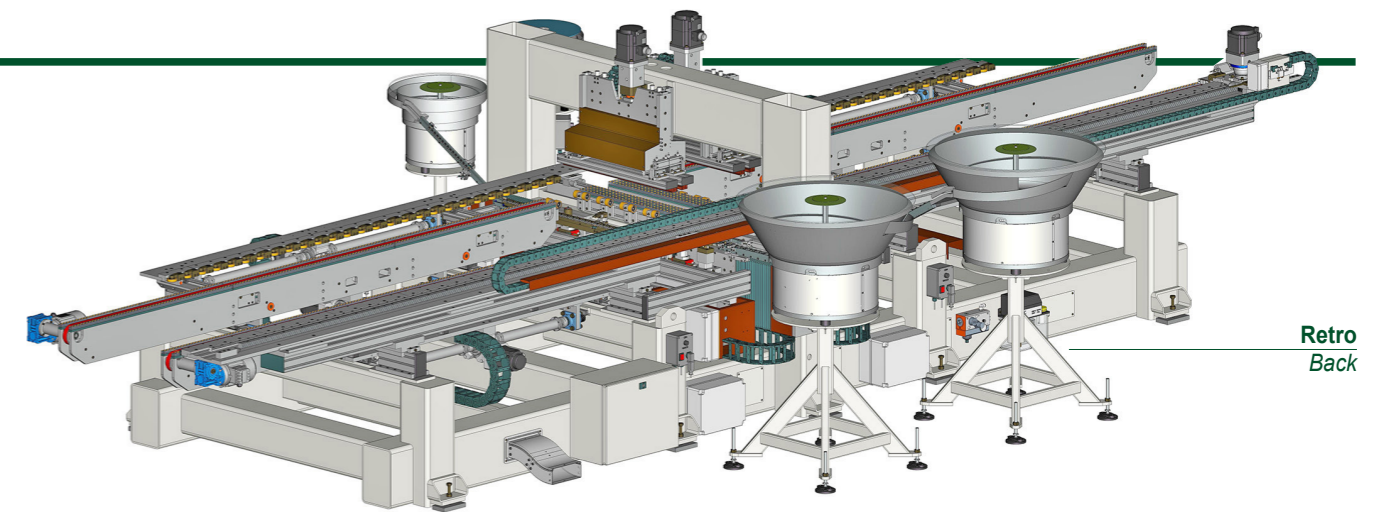
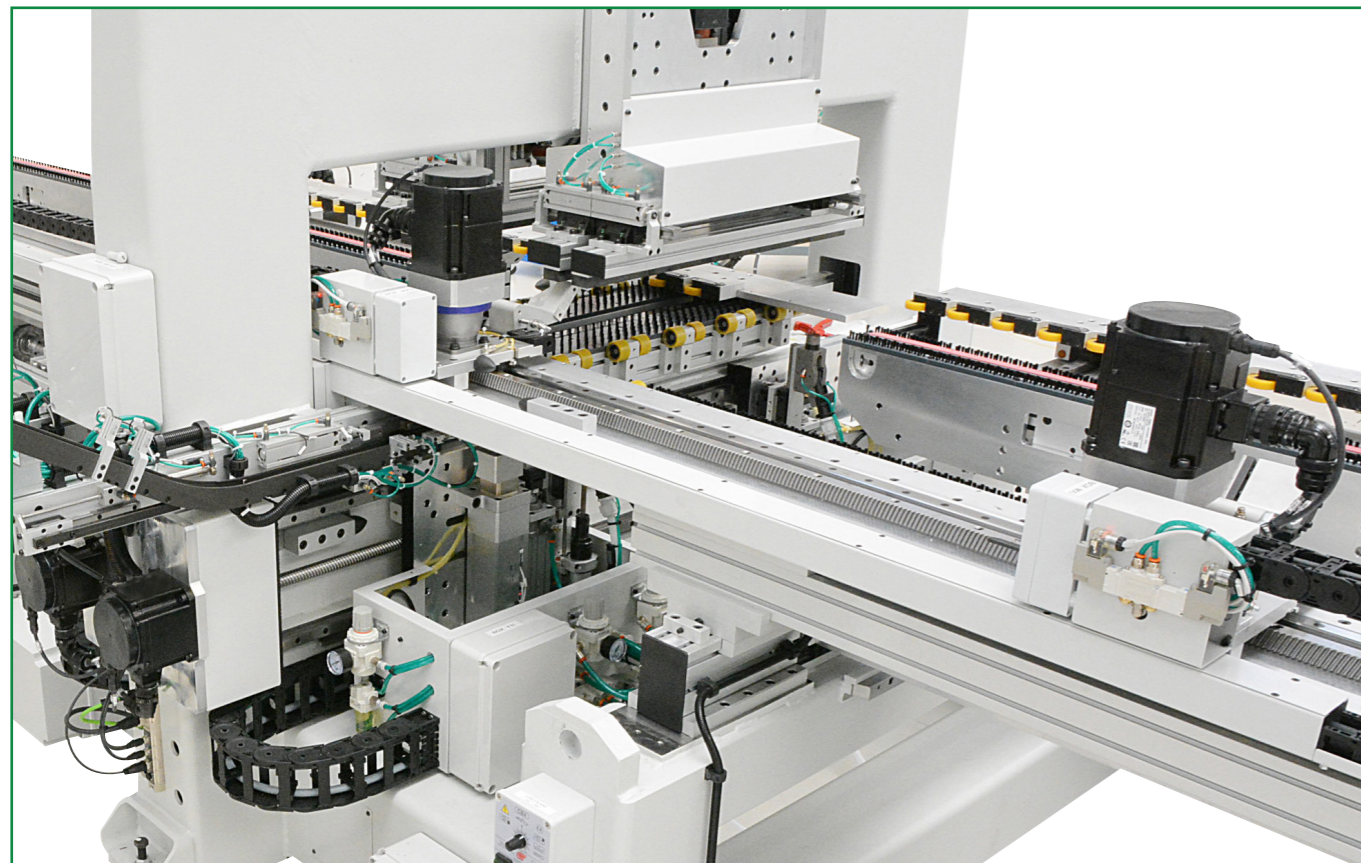

Retro  
Back

Esempi di ferramenta  
Examples of fittings

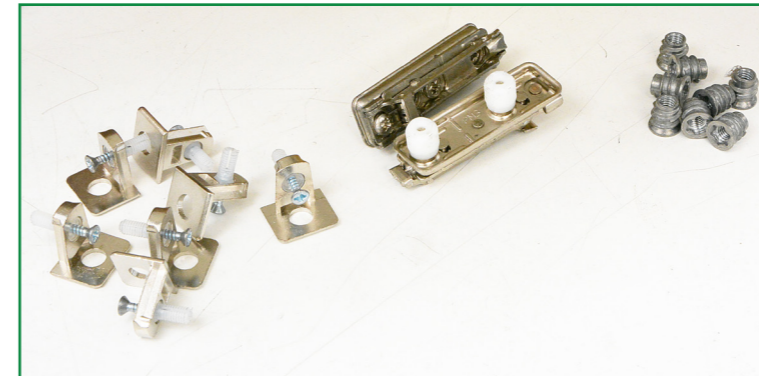

Inserimento supporto ripiano  
Shelf support insertion

